



Features

- Single 3-V supply voltage
- High-power-added efficient power amplifier (P_{out} typ. 23 dBm)
- Ramp-controlled output power
- Current-saving standby mode
- Few external components
- HP-VFQFP-N16

Electrostatic sensitive device.
Observe precautions for handling.



Description

The T7023 is a monolithic SiGe power amplifier. It is especially designed for operation in TDMA systems like Bluetooth, DECT, IEE 802.11 FHSS WLAN, home RF and ISM proprietary radios.

Due to the ramp-control feature and a very low quiescent current, an external switch transistor for V_S is not required.

Block Diagram

Figure 1.

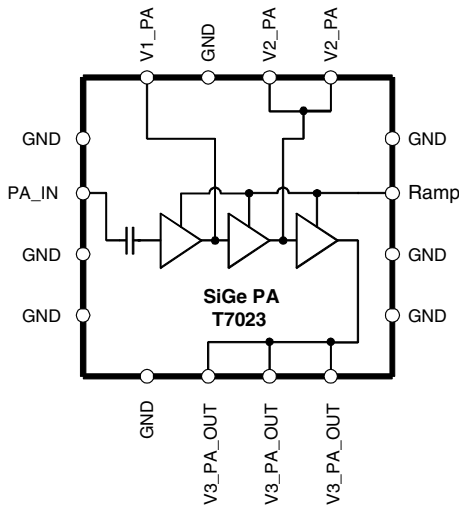

Ordering Information

Extended Type Number	Package	Remarks
T7023-PES	HP-VFQFP-N16	Tube
T7023-PEQ	HP-VFQFP-N16	Taped and reeled
T7023-DB	Flipchip	



ISM/Bluetooth™ 2.4-GHz Power Amplifier

T7023

Rev. A4, 06-Dec-01



Pin Configuration

Figure 2. Pinning HP-VFQFP-N16

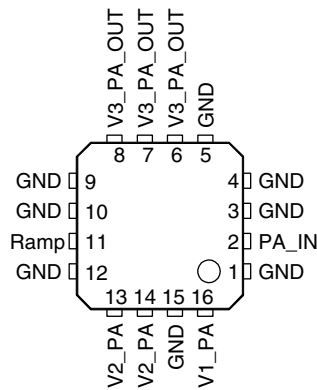

Pin Description

Pin	Symbol	Function
1	GND	Ground
2	PA_IN	Power amplifier input
3	GND	Ground
4	GND	Ground
5	GND	Ground
6	V3_PA_OUT	Inductor to power supply and matching network for power amplifier output
7	V3_PA_OUT	Inductor to power supply and matching network for power amplifier output
8	V3_PA_OUT	Inductor to power supply and matching network for power amplifier output
9	GND	Ground
10	GND	Ground
11	RAMP	Power ramping control input
12	GND	Ground
13	V2_PA	Inductor to power supply for power amplifier
14	V2_PA	Inductor to power supply for power amplifier
15	GND	Ground
16	V1_PA	Supply voltage for power amplifier
Slug	GND	Ground

Absolute Maximum Ratings

All voltages are referred to ground (Pins GND and slug), no RF

Parameter	Symbol	Value	Unit
Supply voltage Pins V1_PA, V2_PA and V3_PA_OUT	V_S	6	V
Junction temperature	T_j	150	°C
Storage temperature	T_{stg}	-40 to +125	°C
RF input power PA	P_{inPA}	10 dBm	dBm

Thermal Resistance

Parameter	Symbol	Value	Unit
Junction ambient HP-VFQFP-N16	R_{thJA}	t.b.d.	K/W

Operating Range

All voltages are referred to ground (Pins GND and slug). Power supply points are V1_PA, V2_PA, V3_PA_OUT. The following table represents the sum of all supply currents depending on the TX mode.

Parameter	Symbol	Min.	Typ.	Max.	Unit
Supply voltage Pins V1_PA, V2_PA and V3_PA_OUT	V_S	2.7	3.0	4.6	V
Supply current	I_S		165		mA
Standby current	I_S		10		μA
Ambient temperature	T_{amb}	-25	+25	+70	°C

Electrical Characteristics

Test conditions (unless otherwise specified): $V_S = 3.0\text{ V}$, $T_{amb} = 25^\circ\text{C}$

No.	Parameters	Test Conditions	Pin	Symbol	Min.	Typ.	Max.	Unit	Type*
Power Amplifier ¹⁾									
	Supply voltage	Pins V1_PA, V2_PA and V3_PA_OUT		V_S	2.7	3.0	4.6	V	
	Supply current	TX		I_{S_TX}		165		mA	
		RX (PA off), $V_{RAMP} \geq 0.1\text{ V}$		I_{S_RX}			10	μA	
		Standby		$I_{S_standby}$			10	μA	
	Frequency range	TX		f	2.4		2.5	GHz	
	Gain-control range	TX		ΔGp	60	42		dB	
	Power gain max.	TX Pin PA_IN to V3_PA_OUT		Gp	28	30	33	dB	
	Power gain min.	TX Pin PA_IN to V3_PA_OUT		Gp	-40		-17	dB	
	Ramping voltage max.	TX, power gain (max) Pin RAMP		$V_{RAMP\ max}$	1.7	1.75	1.83	V	
	Ramping voltage min.	TX, power gain (min) Pin RAMP		$V_{RAMP\ min}$		0.1		V	
	Ramping current max.	$V = 1.75\text{ V}$					0.5	mA	
	Power-added efficiency	TX		PAE	35	40		%	
	Saturated output power	TX, input power = 0 dBm referred to Pins V3_PA_OUT		P_{sat}	22.5	23	23.5	dBm	
	Input matching ²⁾	TX, Pin PA_IN		Load VSWR		<1.5:1	1.5 : 1		
	Output matching ²⁾	TX, Pin V3_PA_OUT		Load VSWR		<1.5:1	1.5 : 1		
	Harmonics @P 1dB _{CP}	TX, Pin V3_PA_OUT		2 fo			-30	dBc	
	Harmonics @P 1dB _{CP}	TX, Pin V3_PA_OUT		3 fo			-30	dBc	
*) Type means: A =100% tested, B = 100% correlation tested, C = Characterized on samples, D = Design parameter									
Notes: 1) Power amplifier shall be unconditional stable, maximum duty cycle 100%, true cw operation, maximum load mismatch and duration t.b.d.									
2) With external matching network, load impedance 50 Ω									

Typical Operating Characteristics

Figure 3. Output power and PAE vs. supply voltage

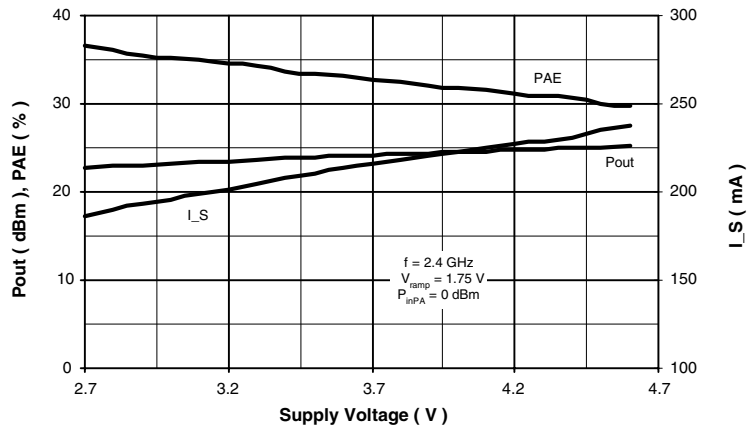

Figure 4. Output power and PAE vs. frequency

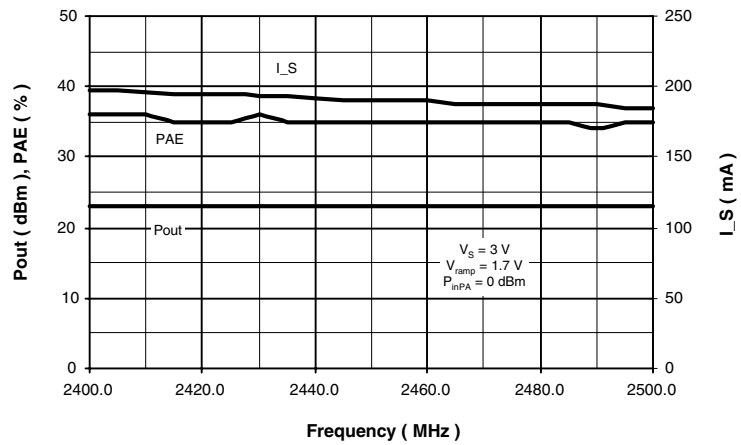

Figure 5. Output power and PAE vs. ramp voltage

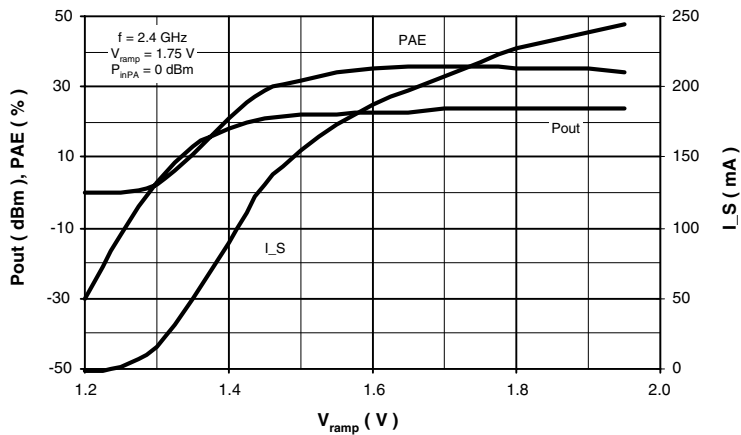

Figure 6. Output power and PAE vs. input power

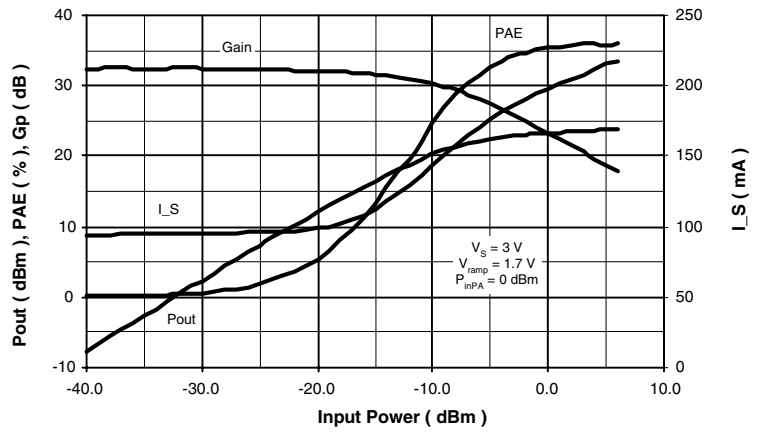

Figure 7. P_{out} vs. V_{ramp} and temperature

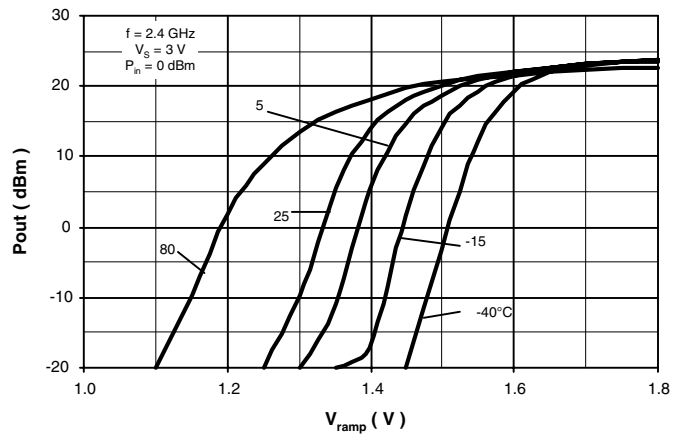

Figure 8.

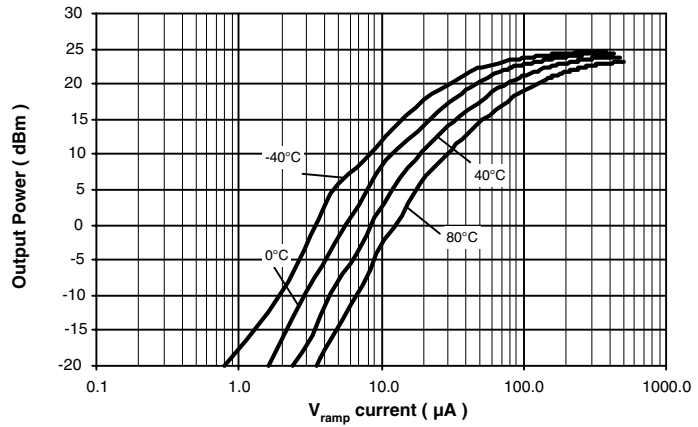
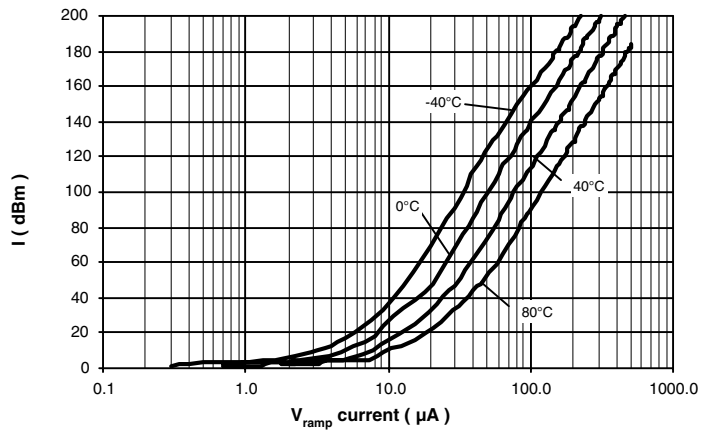

Figure 9.



Input / Output Circuits

Figure 10.

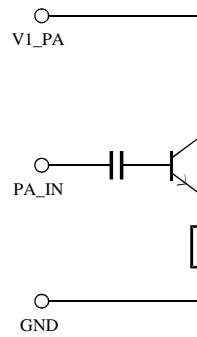

Figure 11.

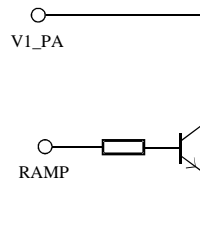

Figure 12.

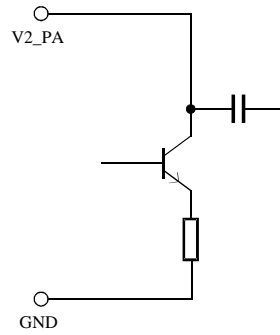
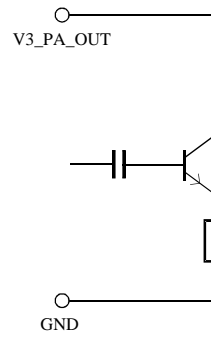
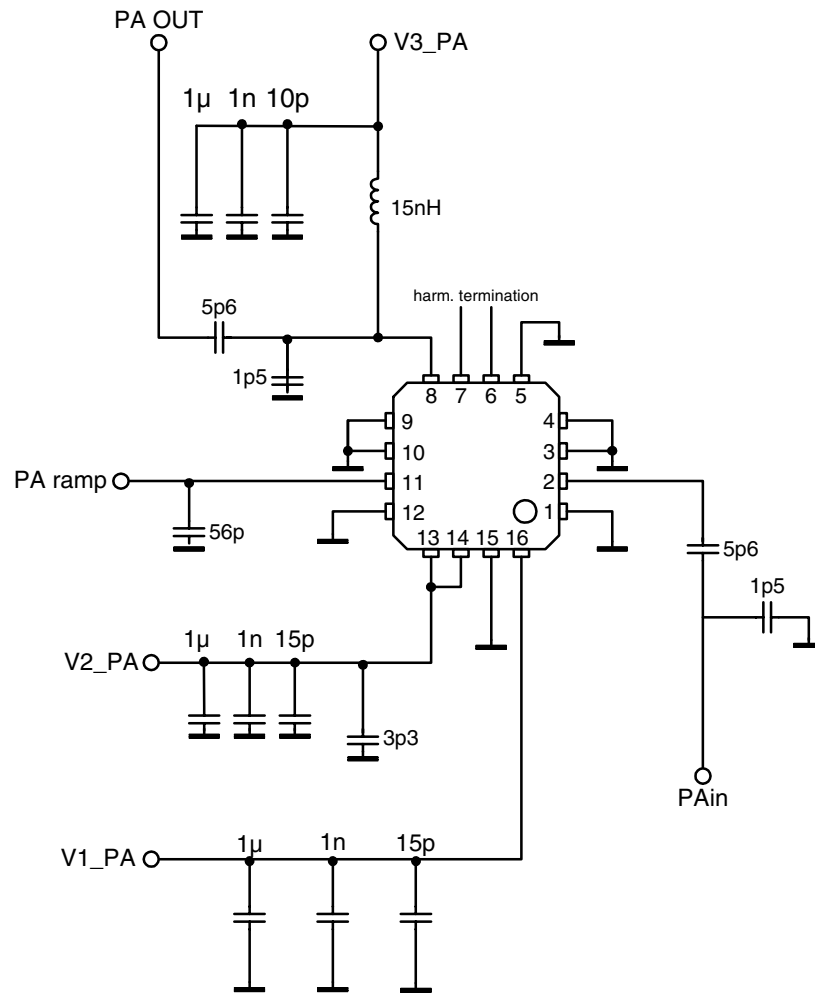

Figure 13.



Application Board Schematic

Figure 14.



Application Board Layout

Figure 15.

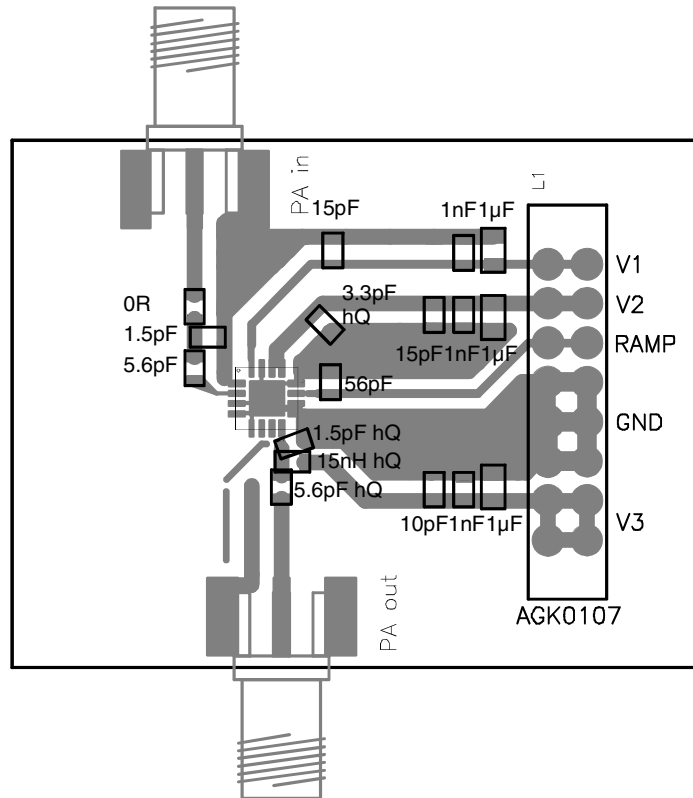

Packaging Information

Package: HP-VFQFP-N16
 Exposed pad Var. A
 (acc. JEDEC OUTLINE No. MO-220)
 Dimensions in mm

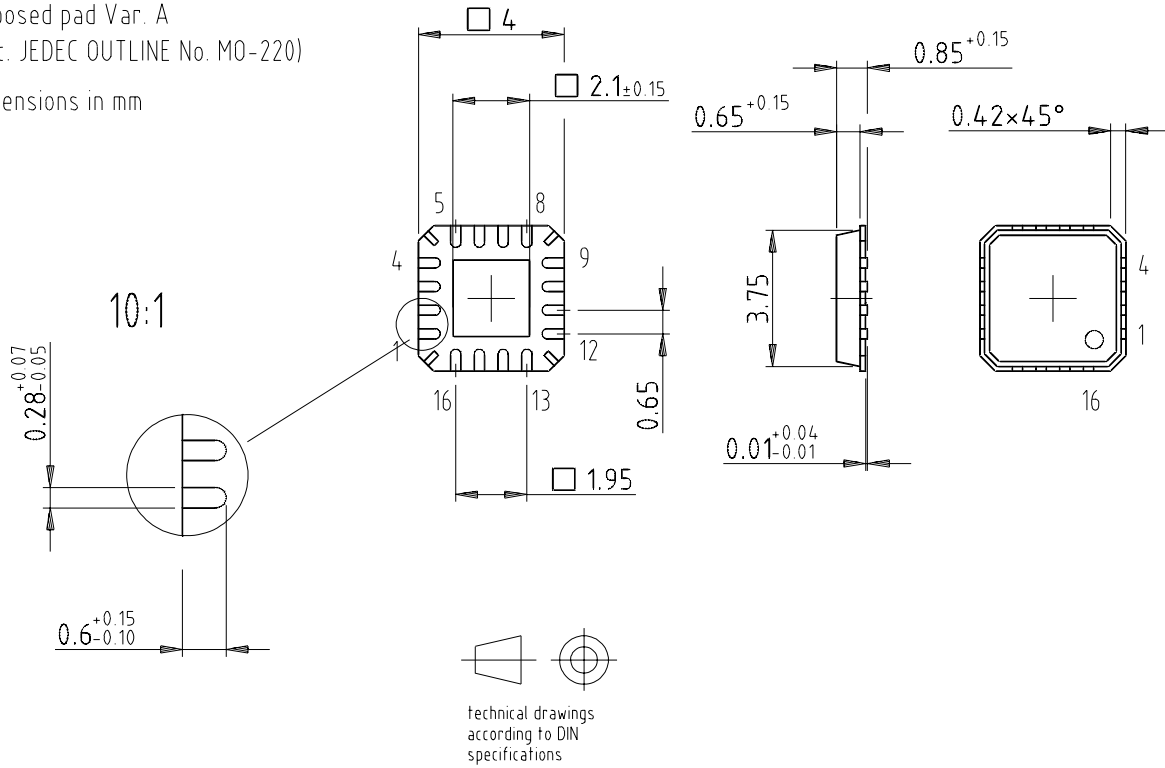

Ozone Depleting Substances Policy Statement

It is the policy of **Atmel Germany GmbH** to

1. Meet all present and future national and international statutory requirements.
2. Regularly and continuously improve the performance of our products, processes, distribution and operating systems with respect to their impact on the health and safety of our employees and the public, as well as their impact on the environment.

It is particular concern to control or eliminate releases of those substances into the atmosphere which are known as ozone depleting substances (ODSs).

The Montreal Protocol (1987) and its London Amendments (1990) intend to severely restrict the use of ODSs and forbid their use within the next ten years. Various national and international initiatives are pressing for an earlier ban on these substances.

Atmel Germany GmbH has been able to use its policy of continuous improvements to eliminate the use of ODSs listed in the following documents.

1. Annex A, B and list of transitional substances of the Montreal Protocol and the London Amendments respectively
2. Class I and II ozone depleting substances in the Clean Air Act Amendments of 1990 by the Environmental Protection Agency (EPA) in the USA
3. Council Decision 88/540/EEC and 91/690/EEC Annex A, B and C (transitional substances) respectively.

Atmel Germany GmbH can certify that our semiconductors are not manufactured with ozone depleting substances and do not contain such substances.



Atmel Sales Offices

France

3, Avenue du Centre
78054 St.-Quentin-en-Yvelines
Cedex
Tel: +33 1 30 60 70 00
Fax: +33 1 30 60 71 11

Germany

Erfurter Strasse 31
85386 Eching
Tel: +49 89 319 70 0
Fax: +49 89 319 46 21

Kruppstrasse 6
45128 Essen
Tel: +49 201 247 30 0
Fax: +49 201 247 30 47

Theresienstrasse 2
74072 Heilbronn
Tel: +49 7131 67 36 36
Fax: +49 7131 67 31 63

Italy

Via Grosio, 10/8
20151 Milano
Tel: +39 02 38 03 71
Fax: +39 02 38 03 72 34

Spain

Principe de Vergara, 112
28002 Madrid
Tel: +34 91 564 51 81
Fax: +34 91 562 75 14

Sweden

Kavallerivaegen 24, Rissne
17402 Sundbyberg
Tel: +46 8 587 48 800
Fax: +46 8 587 48 850

United Kingdom

Easthampstead Road
Bracknell
Berkshire RG12 1LX
Tel: +44 1344 707 300
Fax: +44 1344 427 371

USA Western

2325 Orchard Parkway
San Jose, California 95131
Tel: +1 408 441 0311
Fax: +1 408 436 4200

USA Eastern

1465 Route 31, Fifth floor
Annandale
New Jersey 08801
Tel: +1 908 848 5208
Fax: +1 908 848 5232

Hong Kong

Room #1219,
Chinachem Golden Plaza
77 Mody Road, Tsimhatsui East
East Kowloon, Hong Kong
Tel: +852 23 789 789
Fax: +852 23 755 733

Korea

25-4, Yoido-Dong, Suite 605,
Singsong Bldg.
Youngdeungpo-Ku
150-010 Seoul
Tel: +822 785 1136
Fax: +822 785 1137

Rep. of Singapore

Keppel Building #03-00
25 Tampines Street 92,
Singapore 528877
Tel: +65 260 8223
Fax: +65 787 9819

Taiwan, R.O.C.

8F-2, 266 Sec.1 Wen Hwa 2 Rd.
Lin Kou Hsiang,
244 Taipei Hsien
Tel: +886 2 2609 5581
Fax: +886 2 2600 2735

Japan

Tonetsushinkawa Bldg.
1-24-8 Shinkawa Chuo Ku
Tokyo 104-0033
Tel: +81 3 3523 3551
Fax: +81 3 3523 7581

Web Site

<http://www.atmel-wm.com>

© Atmel Germany GmbH 2001.

Atmel Germany GmbH makes no warranty for the use of its products, other than those expressly contained in the Company's standard warranty which is detailed in Atmel Germany GmbH's Terms and Conditions. The Company assumes no responsibility for any errors which may appear in this document, reserves the right to change devices or specifications detailed herein at any time without notice, and does not make any commitment to update the information contained herein. No licenses to patents or other intellectual property of Atmel Germany GmbH are granted by the Company in connection with the sale of Atmel Germany GmbH products, expressly or by implication. Atmel Germany GmbH's products are not authorized for use as critical components in life support devices or systems.

Bluetooth and the Bluetooth logos are trademarks owned by Bluetooth SIG, Inc., U.S.A. and licensed to Atmel Corporation.

Data sheets can also be retrieved from the Internet: <http://www.atmel-wm.com>